

PROOF OF DELIVERY

ORIGINAL

Office No.: 073 697 7731 • Cell: 073 694 8064 • Email: imraan02@telkomsa.net

Collection Address: _____

Date: _____

Make: _____

Delivery Address: _____

Reg. No.: _____

Vin No.: _____

Milage: _____

ITEM	COMMENT
RADIO/MP3	
MIRRORS	
LICENSE	
LIGHTER	
GPS TV SCREEN	
ASHTRAY	
CARPETS	
FIRST AID KIT	
TRIANGLE	
JACK	
WHEEL SPANNER	
TOW HOOK	
NO. OF KEYS	
TOOLS	
TYRES & MAGS	
HUB CAPS/MAGS RIMS	
SPARE WHEEL	
SERVICE BOOK	
BAGS	
GIFTS	
PERSONAL ITEMS Kept in Vehicle at own risk	
REMARKS	

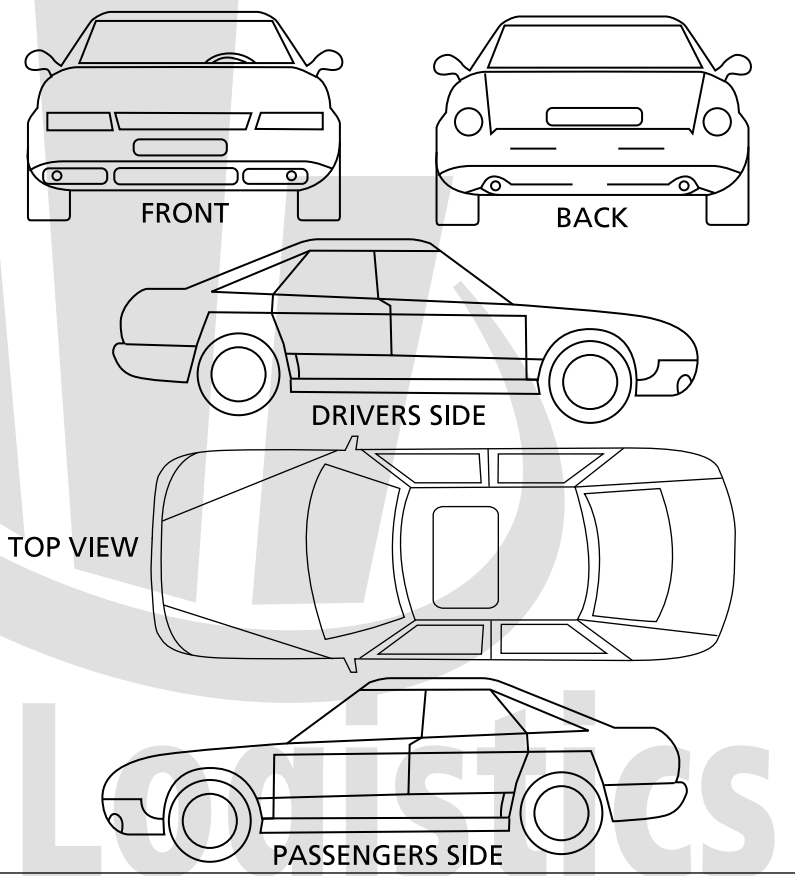

Collected By:

PROOF OF DELIVERY

Print Name _____ Signature _____

DEALER STAMP

Signature of Customer (At Collection Point)

FOR OFFICE USE ONLY

PAID STAMP

Signature Consignee (Dealer) at Delivery Point

Print Name

Please note that all business undertaken is subject to our standard trading condition printed overleaf:
The Merchant confirms that he has read, understood and agrees to be bound by the terms and conditions of the transporter.

DECLARATION BY CUSTOMER:

- i) I have checked all the items listed above and all valuables are removed from vehicle. All personal items that are left in vehicle are at customers own risk and I will not hold M.I.E. Logistics liable for any items that are missing or damaged.
- ii) All vehicles are loaded at the Customers own risk.- No insurance cover on Mechanical & Electrical Breakdowns.
- iii) M.I.E. Logistics will not be held responsible for damage to front spoilers.
- iv) Due to the current road conditions in S.A., our insurance company will not longer insure against damaged windscreens, rims, tyres & stonechips.

PROOF OF DELIVERY

CONSIGNEE COPY

Office No.: 073 697 7731 • Cell: 073 694 8064 • Email: imraan02@telkomsa.net

Collection Address: _____

Date: _____

Delivery Address: _____

Make: _____

Reg. No.: _____

Vin No.: _____

Milage: _____

ITEM	COMMENT
RADIO/MP3	
MIRRORS	
LICENSE	
LIGHTER	
GPS TV SCREEN	
ASHTRAY	
CARPETS	
FIRST AID KIT	
TRIANGLE	
JACK	
WHEEL SPANNER	
TOW HOOK	
NO. OF KEYS	
TOOLS	
TYRES & MAGS	
HUB CAPS/MAGS RIMS	
SPARE WHEEL	
SERVICE BOOK	
BAGS	
GIFTS	
PERSONAL ITEMS Kept in Vehicle at own risk	
REMARKS	

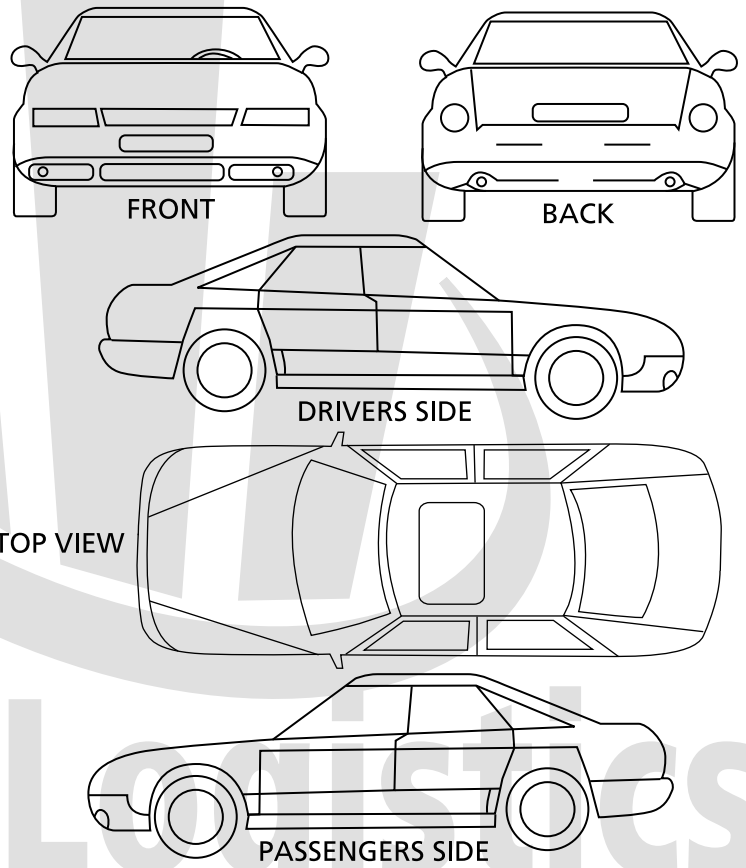

Collected By:

Print Name _____ Signature _____

Signature of Customer (At Collection Point) _____

Signature Consignee (Dealer) at Delivery Point _____

PROOF OF DELIVERY

DEALER STAMP

FOR OFFICE USE ONLY

PAID STAMP

Print Name _____

Please note that all business undertaken is subject to our standard trading condition printed overleaf:
The Merchant confirms that he has read, understood and agrees to be bound by the terms and conditions of the transporter.

DECLARATION BY CUSTOMER:

- i) I have checked all the items listed above and all valuables are removed from vehicle. All personal items that are left in vehicle are at customers own risk and I will not hold M.I.E. Logistics liable for any items that are missing or damaged.
- ii) All vehicles are loaded at the Customers own risk.- No insurance cover on Mechanical & Electrical Breakdowns.
- iii) M.I.E. Logistics will not be held responsible for damage to front spoilers.
- iv) Due to the current road conditions in S.A., our insurance company will not longer insure against damaged windscreens, rims, tyres & stonechips.

PROOF OF DELIVERY

COPY

Office No.: 073 697 7731 • Cell: 073 694 8064 • Email: imraan02@telkomsa.net

Collection Address: _____

Date: _____

Make: _____

Delivery Address: _____

Reg. No.: _____

Vin No.: _____

Milage: _____

ITEM	COMMENT
RADIO/MP3	
MIRRORS	
LICENSE	
LIGHTER	
GPS TV SCREEN	
ASHTRAY	
CARPETS	
FIRST AID KIT	
TRIANGLE	
JACK	
WHEEL SPANNER	
TOW HOOK	
NO. OF KEYS	
TOOLS	
TYRES & MAGS	
HUB CAPS/MAGS RIMS	
SPARE WHEEL	
SERVICE BOOK	
BAGS	
GIFTS	
PERSONAL ITEMS Kept in Vehicle at own risk	
REMARKS	

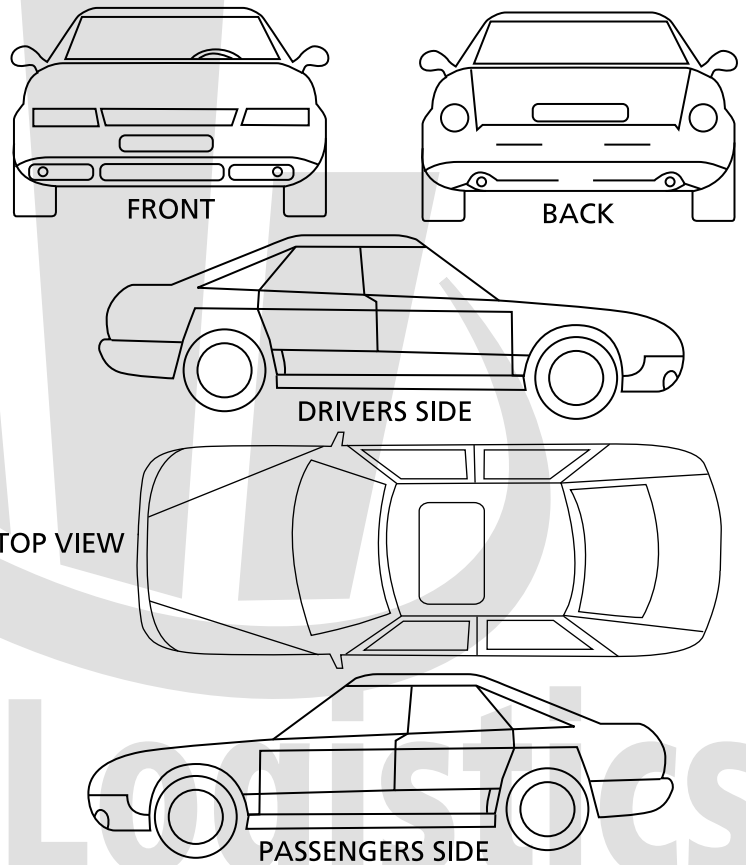

Collected By:

PROOF OF DELIVERY

Print Name _____ Signature _____

DEALER STAMP

Signature of Customer (At Collection Point)

FOR OFFICE USE ONLY

PAID STAMP

Signature Consignee (Dealer) at Delivery Point

Print Name

Please note that all business undertaken is subject to our standard trading condition printed overleaf:
The Merchant confirms that he has read, understood and agrees to be bound by the terms and conditions of the transporter.

DECLARATION BY CUSTOMER:

- i) I have checked all the items listed above and all valuables are removed from vehicle. All personal items that are left in vehicle are at customers own risk and I will not hold M.I.E. Logistics liable for any items that are missing or damaged.
- ii) All vehicles are loaded at the Customers own risk.- No insurance cover on Mechanical & Electrical Breakdowns.
- iii) M.I.E. Logistics will not be held responsible for damage to front spoilers.
- iv) Due to the current road conditions in S.A., our insurance company will not longer insure against damaged windscreens, rims, tyres & stonechips.

MANSOOR IMPORT & EXPORT AGENCIES (PTY) LTD

REGISTRATION NUMBER CK1988/033512/23

STANDARD TRADING TERMS AND CONDITIONS OF CARRIGE OF GOODS BY ROAD

1. DEFINITIONS

For the purpose of the terms and conditions of this agreement unless inconsistent with the context, the following words shall carry the following meanings:

- 1.1 **"Agreement"** means the agreement for the carriage of the Goods by M.I.E for and on behalf of the Customer comprising of the Conditions and the Quotation and "the/this Agreement" shall have a corresponding meaning;
- 1.2 **"Conditions"** mean the Standard Terms and Conditions as set out in this document and/or as supplemented from time to time;
- 1.3 **"Contract"** - means the terms and conditions hereof whether agreed to in writing or orally between M.I.E and the Customer;
- 1.4 **"Customer"** means the person who instructed M.I.E to perform services on its behalf and/or any person who accepts an M.I.E quotation and/or any person entity that contract with M.I.E;
- 1.5 **"Goods"** mean motor vehicles or any articles of any other type and description as described in the Quotation and handed to M.I.E for transportation.
- 1.6 **"Law"** includes the common law, statute, ordinance, by laws and regulations;
- 1.7 **"M.I.E"** means Mansoor Import and Export CC, a Close Corporation registered and incorporated in accordance with the Close Corporation Act _____ having registration number _____;
- 1.8 **"Parties"** mean M.I.E and the Customer;
- 1.9 **"Persons"** shall have its ordinary meaning and includes any legal entity/ juristic person.
- 1.10 **"Quotation"** means the Quotation(s) accepted by the Customer in terms of which M.I.E is appointed by the Customer to transport the Goods on behalf of the Customer, which quotation(s) together with the Conditions form the basis of the Agreement between M.I.E and the Customer;
- 1.11 **"Sub-contractor"** means any person with whom M.I.E sub-contracts to carry out Transportation;
- 1.12 **"Transportation"** - means without restricting the generality of this term, conveyance packing (when necessary), storing and/or safekeeping of any Goods and the acquiring of permits, authority/ies and the like related thereto;

2. APPLICABILITY OF THESE CONDITIONS

- 2.1 The terms and conditions as contained herein together with any addendum thereto and the Quotation shall govern the relationship between M.I.E and the Customer including any additional terms and conditions agreed to between the Parties subsequent to the Customers acceptance of a Quotation.
- 2.2 No warranty or representation other than as is herein expressly contained shall be of any force and effect against M.I.E unless the same is contained in writing and signed by M.I.E

3. TARIFFS AND QUOTATIONS

- 3.1 The Customer shall pay an amount as provided for in the Quotation to the Company as consideration for the transport services rendered by M.I.E in respect of the Goods.
- 3.2 Quotations shall only be valid against and binding upon the Company if accepted by the customer in writing within 7 days of the date thereof, failing which the Company shall be at liberty to withdraw, vary or revise any quotation.
- 3.3 The Company reserves the right to revise any Quotation after acceptance in the following circumstances:
 - 3.3.1 In the event of the Company being obliged to take out or obtain any licenses or permits, or to comply with the requirements of any lawful authority;
 - 3.3.2 In the event of the Customer and/or any third party increasing the consignment or changing the consignment;
 - 3.3.3 In the event of the Company being obliged to deviate from the route selected by it, or to carry the Goods over another route as a result of adverse weather conditions, impassable or dangerous roads and bridges.
 - 3.3.4 In the event of the Company being obliged to take out additional insurance cover as envisaged in clause 4.3 below.
- 3.4 M.I.E shall be entitled at any time by notice to the Customer, to cancel any Quotation in circumstances where in M.I.E's sole and absolute discretion, it becomes impracticable or uneconomical to carry out the Agreement. The Customer shall have no claim whatsoever against M.I.E for any loss thereby incurred.

4. LIMITATION OF LIABILITY

- 4.1 All transport work carried out in terms of the contract is done at the exclusive risk of the Customer.
- 4.2 The Company is not responsible for any loss and/or damages, including consequential damages, which the Customer may suffer as a result of the Transportation service rendered by the Company in terms of the Agreement.
- 4.3 It is recorded that the Company has taken out a Goods in Transit Insurance Policy of R3 500 000.00 (Three and Half Million Rands), excess 10% of claim and minimum 5% of the value.
- 4.4 If a higher insurance policy cover is required for any particular vehicle or load, the Customer shall inform M.I.E in writing as such before the Goods are uplifted for Transportation in order for M.I.E to arrange and put in place an increase in the insurance cover to the value required, which will incur extra charges for the Customer account.
- 4.5 The liability of M.I.E in respect of any loss or damage to the Goods, however such loss may arise, will under no circumstances exceed the actual amount paid by the insurers in terms of the aforesaid Goods in Transit Policy in the event of loss or damage to the Goods.
- 4.6 The Customer shall advise M.I.E of any damages within a period of 24 hours from date of delivery of the Goods such damages shall be recorded on the Proof of Delivery document presented to the Customer or its nominated agent at the time of delivery.
- 4.7 In the event of M.I.E disclaiming liability in respect of any claim, any action or suit for review must be instituted within 1 (one) month of said disclaimer.
- 4.8 Should the Customer not institute action within a 1 (one) month period, the Customer shall not be entitled to proceed for recovery of any amounts against M.I.E in respect of the specific load and shall have no claim in respect of any alleged damages under any circumstances whatsoever.
- 4.9 M.I.E will not accept liability for any personal effects and loose articles placed in any vehicle for Transportation.
- 4.10 M.I.E will not accept liability for mechanical failures and electrical defects that a vehicle may encounter whilst driven under own power on to or off the vehicle transporter. The onus rests upon the Customer to ensure sufficient fluid levels in respect of any vehicle whether it is consigned to own power delivery or carried prior to handover to the M.I.E and M.I.E is exempt from liability of any claim or loss or damage arising there from.
- 4.11 The Customer shall ensure that the vehicle is in a clean condition before collection of the vehicle and ensure that the vehicle is fit for transportation. Any defects that is on the vehicle has to be pointed out to the M.I.E or its representative before handing the vehicle over to M.I.E.
- 4.12 M.I.E shall not be liable for any loss or damage arising from loss of market or attribute to delay in forwarding or in transit or failure to carry out fully or any instruction given to it for any other consequential loss howsoever arising.
- 4.13 No Vintage Vehicles will be covered under G.I.T. Insurance
- 4.14 No Accident Damage or non-running vehicles will be covered under G.I.T. Insurance.

5. CUSTOMER WARRANTIES AND INDEMNITIES

The Customer warrants and represents that:

- 5.1 The Goods are the Customers sole and exclusive property and that the Customer has full and absolute authority of the persons owning or interested in the Goods to enter into this Agreement.
- 5.2 The carriage of the Goods as contracted for with M.I.E does not contravene any law.
- 5.3 That it has disclosed to M.I.E all material information pertaining to transportation and which may effect M.I.E decision in agreeing to transport the Goods for and on behalf of the Customer.
- 5.4 The Customer warrants the accuracy, without exception, of all information and specifications in respect of the Goods given by or on its behalf to M.I.E.
- 5.5 The Customer acknowledges that each of the above warranties are separate and material and goes to the root of this Agreement and M.I.E has agreed to render the Transportation Services on the strength of each of such warranties.

6. PAYMENT WITHOUT DEDUCTION

Notwithstanding any such notification of claim as set forth in this agreement, the Customer shall pay to M.I.E the full amount stated on M.I.E invoice on due date without deduction or set off and without prejudice to the Customers rights contended for against M.I.E in respect of any such claim the Customer shall not be entitled to deduct or set off any monies which it owes to M.I.E against any monies which it contends are due to it by either.

7. PAYMENT

- 7.1 Payment shall be received in full, free of any commission, exchange, brokerage, deduction or set off, at the time of delivery or solely within the discretion of M.I.E at the presentation of invoice or on agreement within 30 days of date of invoice by M.I.E.
- 7.2 Notwithstanding that M.I.E may agree to collect or receive payment from a third party, the Customer hereby guarantees payment of the invoice value by such third party to M.I.E.
- 7.3 There will be no valid discharge of the obligation to pay M.I.E by the Customer unless payment has been made to M.I.E and to no other person whomsoever.
- 7.4 M.I.E is entitled to levy an interest charge against the Customer at the maximum rate permitted by the Credit Act on all amounts which are outstanding and are unpaid by the Customer.

8. CONDITION OF GOODS

- 8.1 The Customer shall be obliged to fill in a checklist prior to handing over the Goods to M.I.E
- 8.2 In the event of the checklist not being completed as aforesaid the Customer shall be disentitled to claim for any damages whatsoever of whatever nature howsoever arising.
- 8.3 The waybill shall constitute proof of the condition of the Goods, save to the extent that any specific record in relation thereto may have been made thereon by M.I.E.

9. LOADING AND OFF LOADING FACILITIES

The Customer shall:

- 9.1 Provide adequate loading and off loading points and access to any such loading and off loading points
- 9.2 Ensure loading and off loading will be possible at the agreed points during such hours and days as the parties have agreed
- 9.3 Ensure all Goods loaded shall be in such condition as enable due off loading to be freely effected at the point of destination of such loading.

10. DELAYS AND DAMAGES

- 10.1 In the event of a vehicle being delayed or damaged due to the Customers failure to perform any task, the Customer shall be liable for additional charges at M.I.E usual rates, alternatively reasonable rates and such damages as the case may be.
- 10.2 Goods left in M.I.E or the sub-contractor vehicle for any reason to suit the convenience of the Customer, are held at the sole risk of the Customer as the case may be. Goods may be held at M.I.E's warehouse or any place at the sole discretion of M.I.E or the sub-contractor, at the Customers risk and expense.

11. FAILURE BY THE CUSTOMER TO TAKE DELIVERY

Should the Customer fail, neglect or refuse to take delivery of the whole or any part of the Goods at the agreed off loading point or time, or should it not be possible to off load the Goods within the prescribed time set out in the agreement, and should no acceptable explanation be received from the Customer relating to its failure, refusal or neglect to receive delivery of the Goods, M.I.E shall store the Goods at its discretion in such event the Customer will be liable to pay any additional charges and shall have no claim whatsoever against M.I.E for any act or omission arising there from.

12. DANGEROUS GOODS

- 12.1 M.I.E is has no authority to carry hazardous goods of whatever nature and no such cargo may be loaded onto any of M.I.E's vehicles without the prior explicit written consent of M.I.E.
- 12.2 M.I.E and the Customer agree that should any claim for damages and/or pollution and/or environmental damages and/or cleanup costs arise consequential to the carriage of hazardous and/or dangerous goods, then all such claims will be for the Customer's account.

13. BREACH

Should the Customer breach any terms or conditions of the Agreement, M.I.E the Customer written notice to remedy such breach within 7 days of receipt thereof, and in the event of the Customer failing to comply therewith, M.I.E shall be entitled to forthwith cancel this agreement and claim immediate payment of all amounts due to it notwithstanding that the due date for payment of such amounts may not yet have arrived, alternatively claim immediate specific performance of all of the Customer's obligations whether or not due for performance, without prejudice to M.I.E's right to claim damages it has suffered damages as a consequence of the Customers breach.

14. JURISDICTION

- 14.1 This Agreement shall be interpreted and governed by the laws of the Republic of South Africa.
- 14.2 M.I.E and the Customer hereby consent to the jurisdiction of any Magistrates Court having jurisdiction over the Customer should M.I.E in its sole and unfettered discretion elect to institute any action arising out of contract against the Customer in such court, notwithstanding the M.I.E claim may exceed the ordinary jurisdiction of such court.
- 14.3 In the event that M.I.E does institute any action against the Customer for whatsoever reason then M.I.E shall be entitled to recover from the Customer legal fees on the attorney and own client scale.

15. LIEN

- 15.1 M.I.E shall have a lien over all Goods as security for all monies owing to it by the Customer.
- 15.2 M.I.E shall hold all Goods as security for any monies which have been due and payable to it by the Customer for any cause whatsoever at the Customers cost and expense.
- 15.3 If any monies owing are not paid within 30 days after they become due, M.I.E shall sell the Goods without further notice to the Customer, over which M.I.E has a lien and to apply the proceeds of any such sale towards any amount due to it by the Customer without prejudice to M.I.E's rights to claim any shortfall amount from the Customer.
- 15.4 Upon payment or tender of the proceeds of any such sale M.I.E shall be released from all liability to the Customer in respect of the Goods.

16. GENERAL

- 16.1 M.I.E may cede, delegate, assign or sub-contract any or all of its rights or obligations under a contract.
- 16.2 These conditions shall apply to any other additional work or transport carried out for and on behalf of the Customer, whether or not the Customers attention has been drawn to these terms and conditions.
- 16.3 The head notes to the various clauses contained in these conditions are for reference purposes only and does not affect the interpretation of the individual clause.
- 16.4 Each of the terms hereof is severable from the rest of the terms contained herein, which terms will remain of full force and effect, should any term be found to be invalid for any reason or without limiting the generality hereof, contra bona mores.
- 16.5 This Agreement constitutes the whole of the agreement between the parties relating to the subject matter thereof, and no amendment, alteration, addition, variation or consensual cancellation will be of any force or effect unless reduced to writing and signed by the Parties. The Parties agree that no other terms or conditions, whether oral or written, and whether express or implied, apply.
- 16.6 This Agreement shall be binding on either Party's nominees, trustees, executors and assigns.

